

Silvercnc Tool Setter - MK-P11-10

specifications

Product name	MK-P11-10
Contact diameter	Ø5mm
Surface finishing	Grinding 4s
Contact material	Tungsten carbide
Contact structure	NC (Normally closed)
Pretravel	0
Stroke	3mm
Repeatability	0.001 (Recommended operating speed of 50 - 200mm/min)
Contact life time	3 million
Protective structure	IP67
Contact force	1.5N (Installation position: Vertical)
Cable	Oil resistant, standard 3 m (length can be customized) φ5/ 2cores
LED lamp	NONE
Over travel signal (built-in microswitch)	
Output mode	NONE
Contact rating	NONE

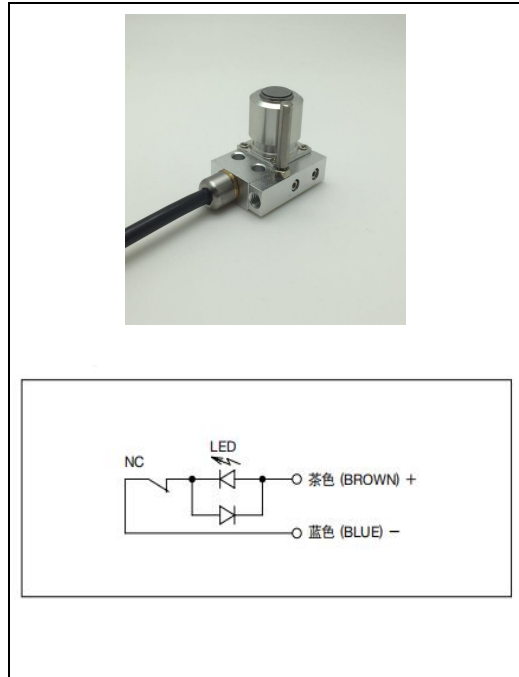

Dimension

