

# Silvercnc Tool Setter - MK-P21-10

## specifications

<b>Product name</b>	<b>MK-P21-10</b>
Contact diameter	Ø10mm
Surface finishing	Grinding 4s
Contact material	Tungsten carbide
Contact structure	NC (Normally closed)
Pretravel	0
Stroke	5mm
Repeatability	0.001(Recommended operating speed of 50 - 200mm/min)
Contact life time	3 million
Protective structure	IP67
Contact force	1.5N (Installation position: Vertical)
Cable	Oil resistant, standard 3 m (length can be customized)4core
LED lamp	NONE
<b>Over travel signal (built-in microswitch)</b>	
Output mode	NC normally closed (an emergency stop when the signal broken )
Contact rating	DC24V 20 mA resistive load

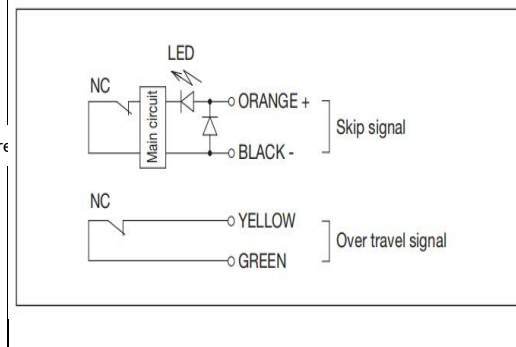

## Dimension

