

5axis rotary table specification (SC-RT650)

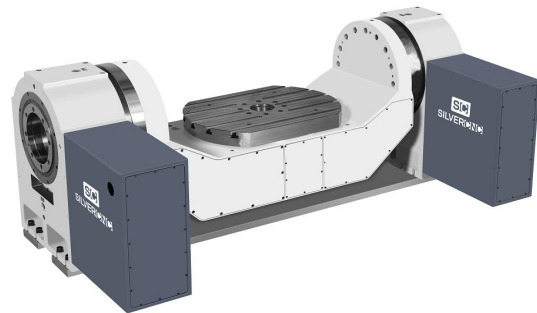

Advantages

The 5 axis rotary table is Roller CAM Driver one of the finest motion control mechanisms available. The unit is constructed from an input shaft (the roller gearcam) and a turret (output shaft) fitted with roller followers. The roller followers are preloaded against a screw-like input shaft to completely eliminate backlash. Our proprietary adjustment mechanism provides optimum preload. The roller followers lanted in the turret use internal roller bearings to transfer torque while rotating. This ensures zero backlash, outstanding precision, and excellent efficiency without causing wear, while providing long-term consistent accuracy

- 1、 No backlash(play) during the clockwise/anti-clockwise rotation
- 2、 No wear because power transfers through rolling contact
- 3、 High accuracy and good efficiency
- 4、 Preload and high rigidity



Specs

Description		Unit	SC-RT650	
Table Diameter		mm	650*480	
Table Height (Vertical)		mm	350	
Diameter of Table Central Hole		mm	φ120H7	
T-Slot		mm	18H7	
Allowable Workpiece Load	Vertical 	kg	350	
	Horizontal 	kg	500	
Net Weight (servo motor excluded)		kg	1800	
Axis		/	Rotary axis	Tilt axis
Cooling System		/	Free Colling	
Transmission Mechanism		/	Roller Gear Cam	
Angle range		/	360°	±120°
Min. Increment		deg.	0.001	0.001
Speed Reduction Ratio		/	1/120	1/180
Rated / Max. Speed		rpm.	16.6	11.1
Indexing Precision		sec.	±20	±40
Repeatability		sec.	±4	±4
Clamping System(Hydraulic)		Mpa	4.5	4.5
Clamping Torque		N.m	2860	5000
Servo Motor Model	FANUC	Taper / Straight	α12iF /β22is	α22iF /β30is
	MITSUBISHI	Straight	HF204S	HF354S
	BROTHER	Straight	1FK7083	1FK7101
	YASKAWA	Straight	SGMGV-30A	SGMGV-44A