

SC-C255 Specification

Introduction

1. Roller CAM struture, no backlash, high accuracy and efficiency
2. Platter Diameter 255mm, hydraulic brake
3. Suitable for installation on 1050mm travel VMC

Dimensions	Table Diameter	mm	Ø255
	Diameter of Table Central Hole	mm	Ø75H7
	Center Height (Vertical)	mm	210
	T slot width	mm	12H7
	Guide Block width		18h7
	Net Weight (servo motor excluded)	kg	125

Roller CAM	Gear Ratio	/	50
	Max. Rotation(Calculate with Fanuc α Motor)	rpm	60
	Resolution	°	0.001
	Indexing Precision	sec.	±20
	Repeatability	sec.	±4



Allowable Workpiece Load			Clamping system		Allowable load (rotary table clamping)		
Vertical/kg	Horizontal/kg	With tailstock/kg	pressure/MPa	Torque/N.m	F(N)	FXL(N.m)	FXL(N.m)
150	300	300	4±0.5	980	24000	980	1650

Servo motor							
FANUC		MITSUBISHI	YASKAWA	SIMENS	SYNTEC	HEIDENHAIN	GSK
α	β						
aiF8	β is12	HG154S-D47	SGM7G-09A	1FK7063	S08-AM11-30	QSY116E	130SJT-M100D

SC-C255 Dimensions

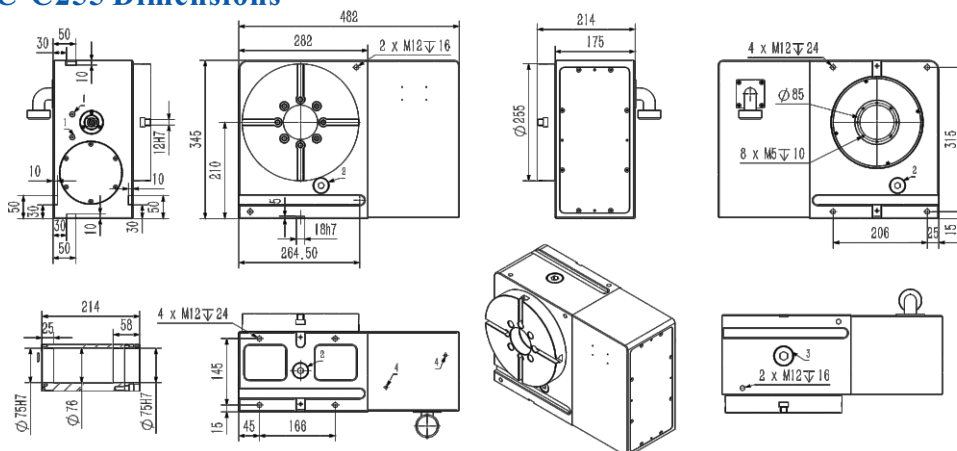

1. 刹车液压口 Brake hydraulic port
2. 排油孔 Oil of outlet
3. 进油口 Oil of inlet
4. 排水口 Drain hole